

JVC

SCHEMATIC DIAGRAMS

COMPACT VHS CAMCORDER

GR-SXM55EK

CD-ROM No. SML200107

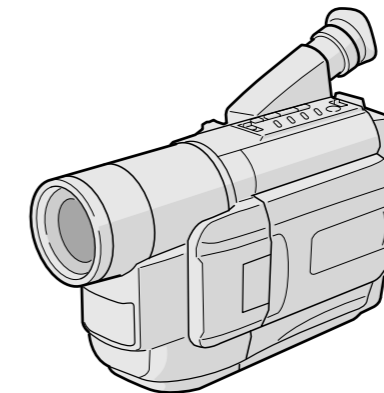

S VHS VHS
PAL
625
Super VHS
Super VHS ET

Regarding service information other than these sections, refer to the GR-SXM607EK service manual (No. 86589). Also, be sure to note important safety precautions provided in the service manual.

SPECIFICATIONS *(The specifications shown pertain specifically to the model GR-SXM607EK/55EK)*

Camcorder	
General	
Format	: S-VHS/VHS PAL standard
Power source	: DC 11 V --- (Using AC Adapter) DC 6 V --- (Using battery pack)
Power consumption	
Viewfinder on	: 4.0 W
LCD monitor on	: 4.5 W
Video light*	: 3.0 W
*GR-SXM607 only.	
Signal system	: PAL-type
Video recording system	
Luminance	: FM recording
Colour	: Converted sub-carrier direct recording Conforms to VHS standard
Cassette	: S VHS / VHS cassette
Tape speed	
SP	: 23.39 mm/sec.
LP	: 11.70 mm/sec.
Recording time (max.)	
SP	: 60 minutes
LP	: 120 minutes (with EC-60 cassette)
Operating temperature	: 0°C to 40°C
Operating humidity	: 35% to 80%
Storage temperature	: -20°C to 50°C
Weight	: Approx. 910 g (GR-SXM607 only) Approx. 900 g (GR-SXM55 only)
Dimensions (W x H x D)	: 200 mm x 112 mm x 118 mm (with the LCD monitor closed and with the viewfinder full tilted downward)
Pickup	: 1/4" format CCD
Lens	: F1.6, f = 3.9 mm to 62.4 mm, 16:1 power zoom lens with auto iris and macro control, filter diameter 40.5 mm
Viewfinder	: Electronic viewfinder with 0.5" black/white CRT
White balance adjustment	: Auto/Manual adjustment
LCD monitor	: 3" diagonally measured, LCD panel/TFT active matrix system (GR-SXM607 only) 2.5" diagonally measured, LCD panel/TFT active matrix system (GR-SXM55 only)
Speaker	: Monaural
Connectors	
JLIP/EDIT	: $\text{ø}3.5$ mm, 4-pole, mini-head jack (compatible with RC-5325 plug)
Video	: 1 V (p-p), 75 Ω unbalanced, analogue output (via Video output connector)
Audio	: 300 mV (rms), 1 k Ω analogue output (via Audio output connector)
S-Video	: Y : 1 V (p-p), 75 Ω , analogue output C : 0.29 V (p-p), 75 Ω , analogue output
AC Adapter AP-V10EG	
Power requirement	: AC 110 V to 240 V \sim , 50 Hz/60 Hz
Output	: DC 11 V --- , 1 A
Dimensions (W x H x D)	: 59 mm x 31 mm x 84 mm
Weight	: Approx. 140 g (not including Power Cord)
Optional Accessories	
• Battery Packs BN-V12U, BN-V20U, BN-V400U	
• Compact S-VHS (S VHS) Cassettes SE-C45/30	
• Compact VHS (VHS) Cassettes EC-60/45/30	
• Remote Control Unit RM-V700U	
• Active Carrying Bag CB-V7U	
• Cassette Adapter C-P7U	
Some accessories are not available in some areas. Please consult your nearest JVC dealer for details on accessories and their availability.	

Specifications shown are for SP mode unless otherwise indicated. E & O.E. Design and specifications subject to change without notice.

JVC

VICTOR COMPANY OF JAPAN, LIMITED
VIDEO DIVISION

S40894

Printed in Japan

This schematic diagrams is printed on 100% recycled paper.
COPYRIGHT © 2001 VICTOR COMPANY OF JAPAN, LTD.

No. 86649SCH
June 2001

SECTION 4 CHARTS AND DIAGRAMS

4.1 BOARD INTERCONNECTIONS

5

4

3

2

1

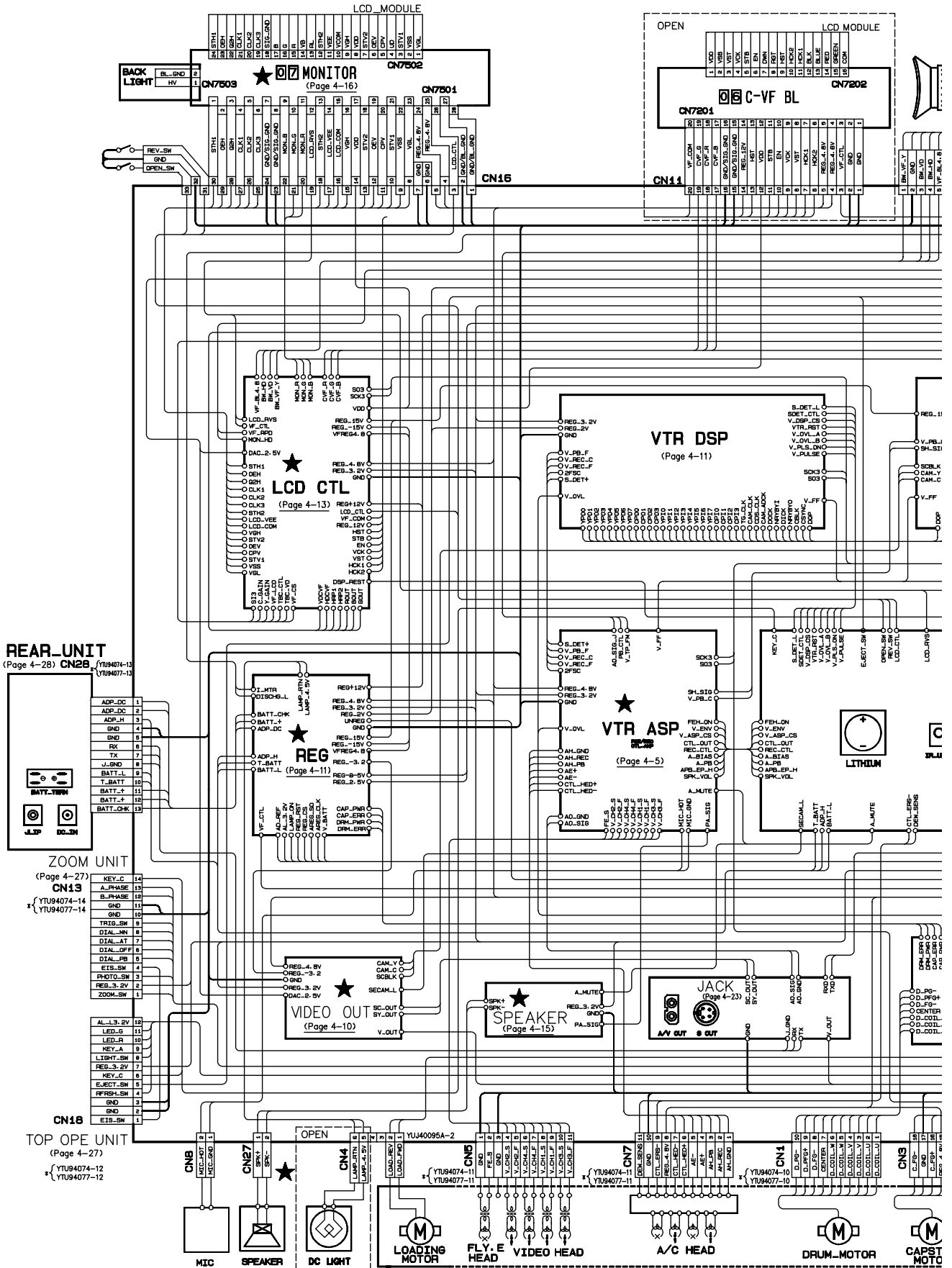

A

B

C

D

Note 1: How to find the page showing the continuative schematic diagram
Example) TO DSP (Page 4-7): Refer to the GR-FXM37EG, SXM607EG/EK service manual (No. 86589).
TO DSP (Page 4-7): Refer to this service manual.

2: The mark ★ means modified points.

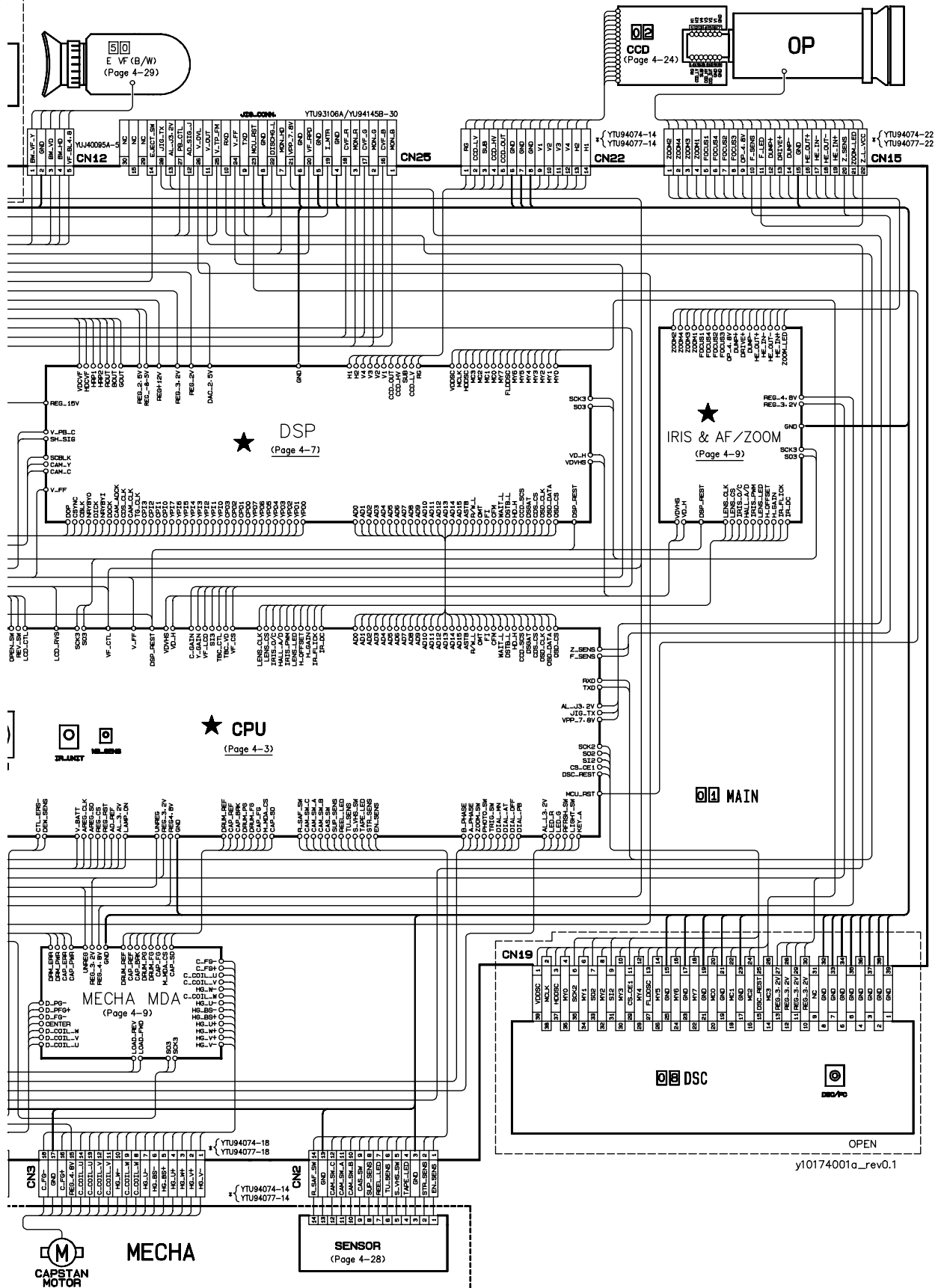

E F G H

4.2 CPU SCHEMATIC DIAGRAM

5

4

3

2

1

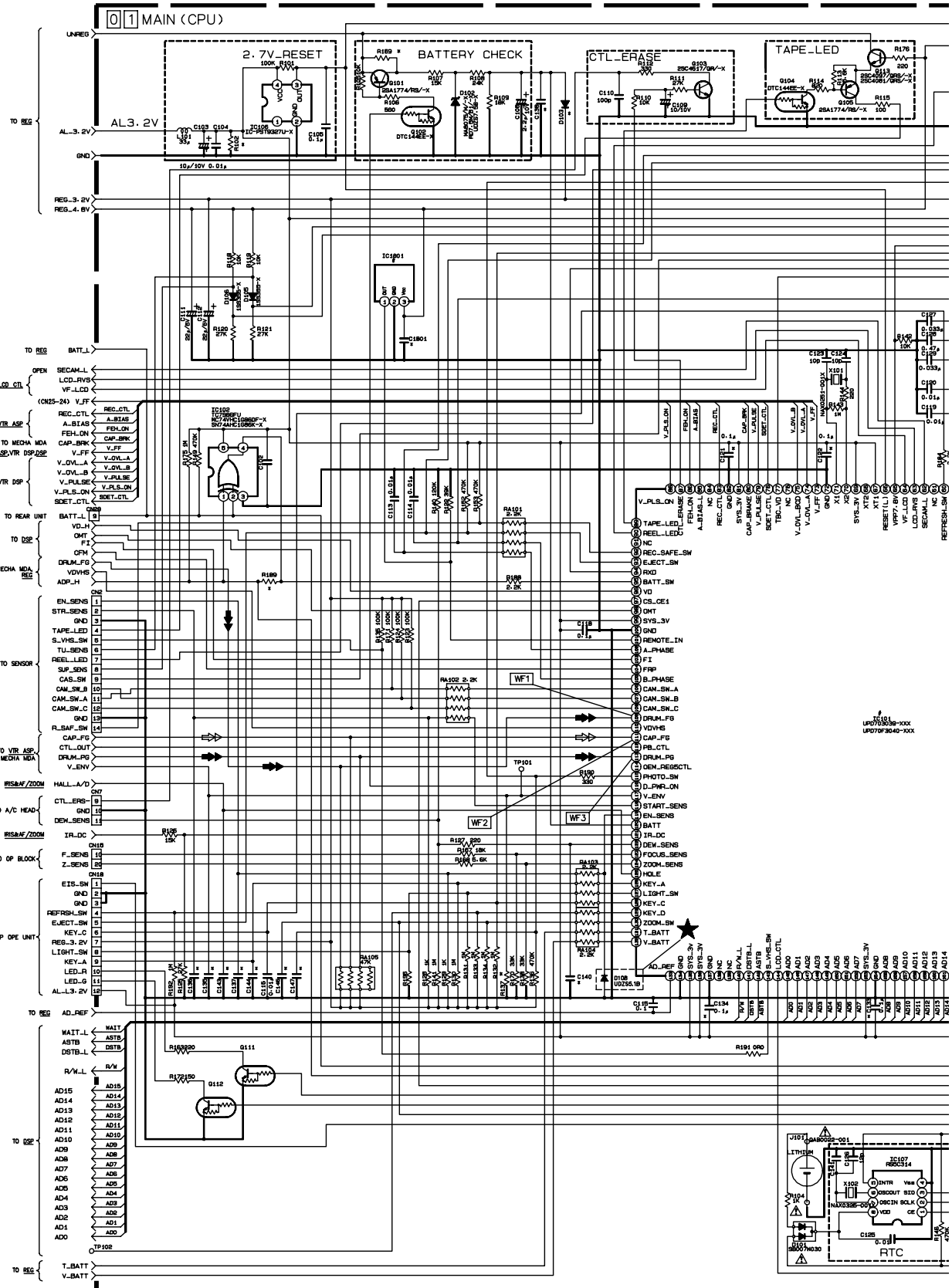

NOTES: 1. THE PARTS WITH MARKED (*) IS NOT USED.
 2. For CPU waveforms, please refer to page 4-55.
 3. The mark ★ means modified points.

A B C D

4.3 VTR ASP SCHEMATIC DIAGRAM

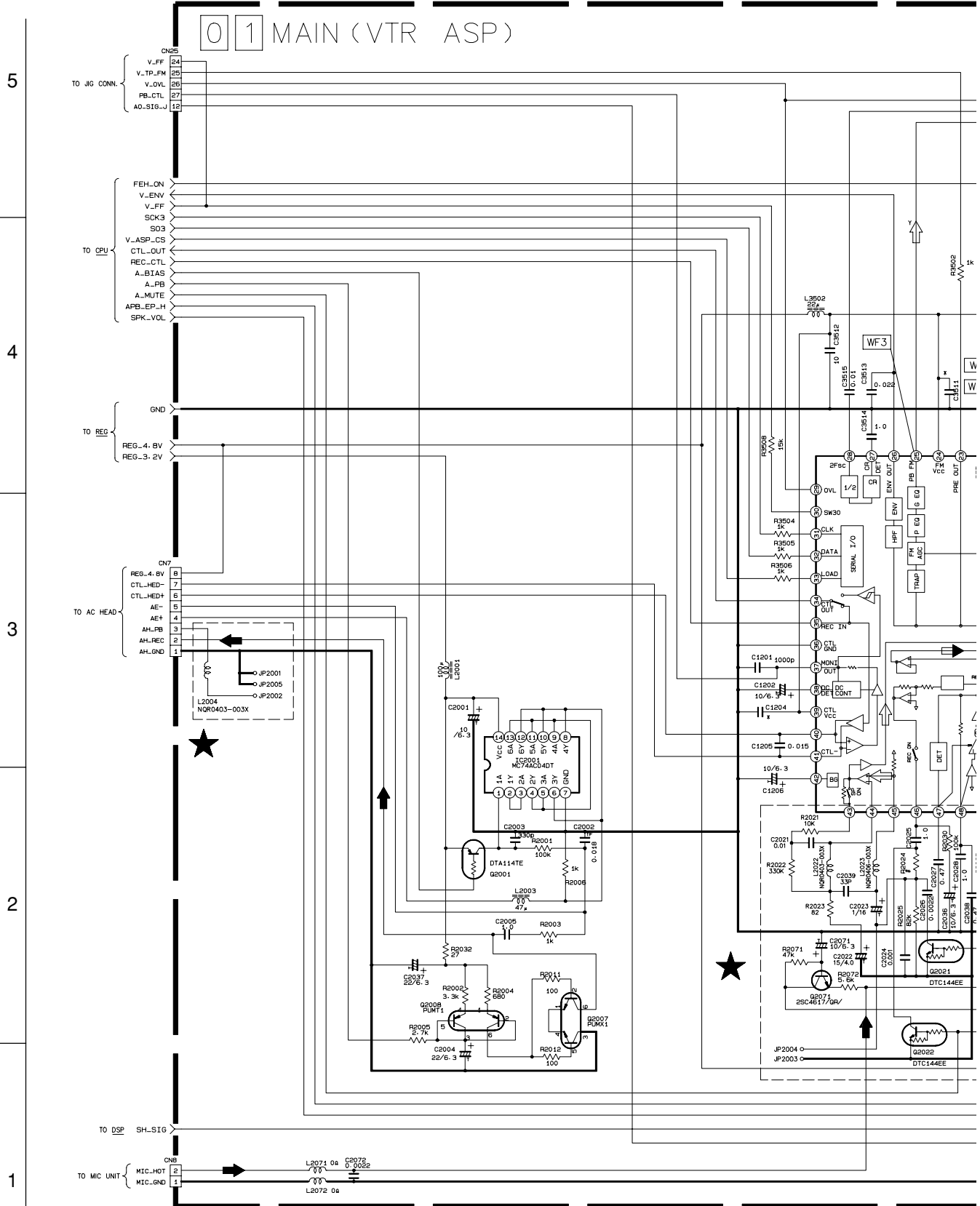

NOTES: 1. THE PARTS WITH MARKED (*) IS NOT USED.
 2. For VTR ASP waveforms, please refer to page 4-55.
 3. The mark ★ means modified points.

- NOTES:**
- For the destination of each signal and further line connections that are cut off from this diagram, refer to “4.1 BOARD INTERCONNECTIONS”.
 - When ordering parts, be sure to order according to the Part Number indicated in the Parts List.

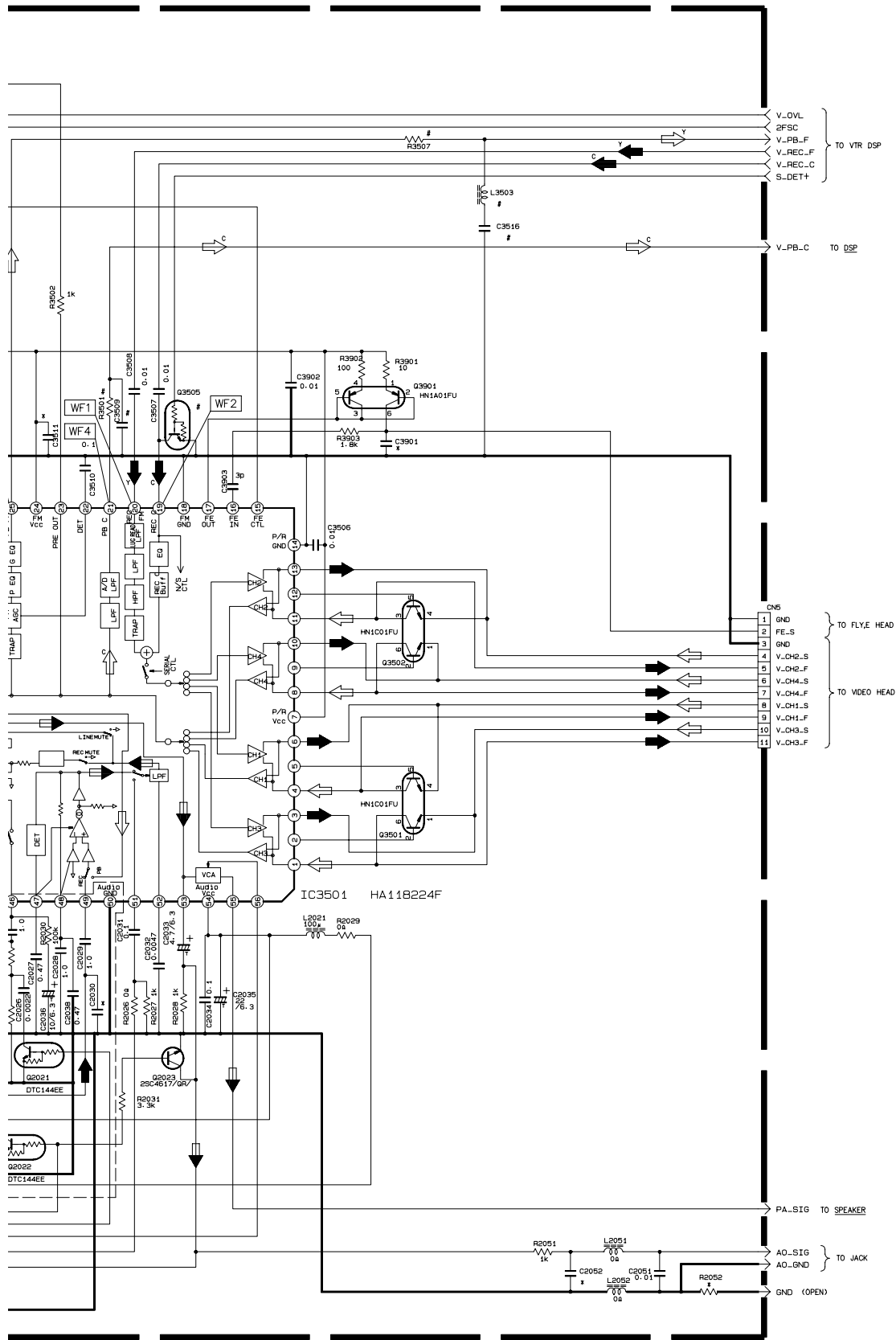

y20114001a_rev0.1

Note: How to fins the page showing the continuative schematic diagram.
 Example) TO DSP : Refer to the reference model's service manual.
 TO DSP : Refer to this service manual.

4.4 DSP SCHEMATIC DIAGRAM

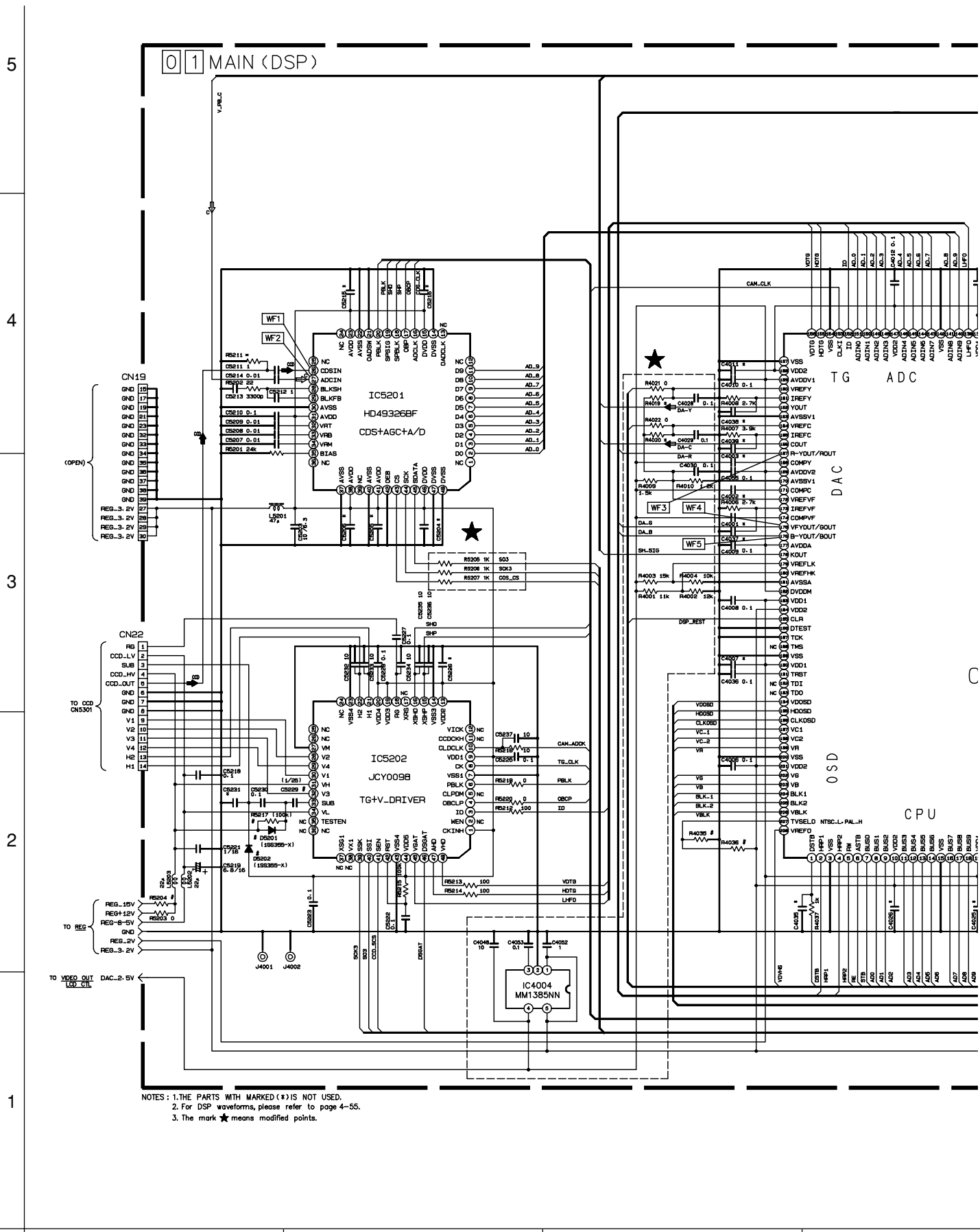

NOTES: 1. THE PARTS WITH MARKED (*) IS NOT USED.
 2. For DSP waveforms, please refer to page 4-55.
 3. The mark * means modified points.

- NOTES:**
- For the destination of each signal and further line connections that are cut off from this diagram, refer to "4.1 BOARD INTERCONNECTIONS".
 - When ordering parts, be sure to order according to the Part Number indicated in the Parts List.

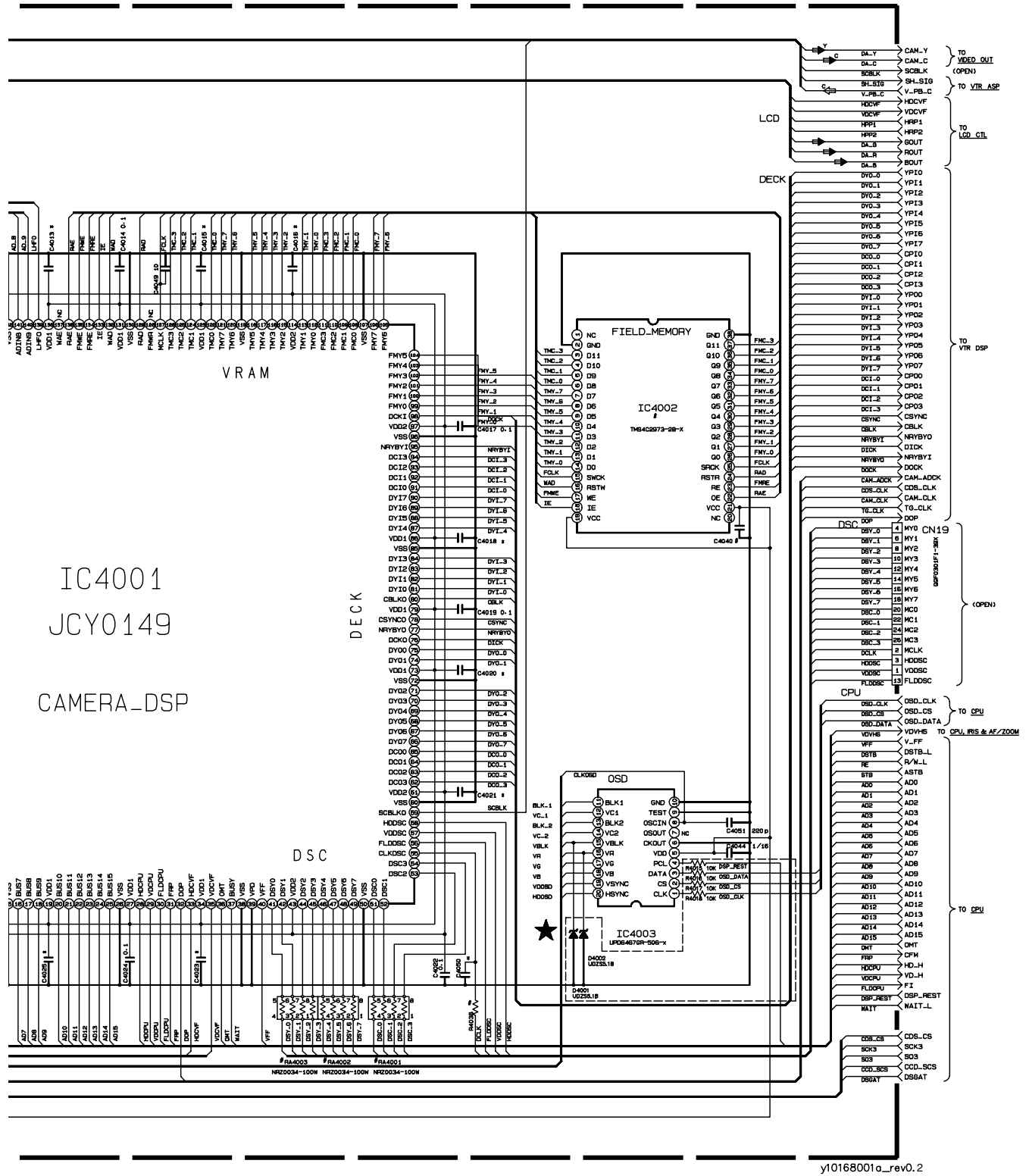

Note : How to find the page showing the continuative schematic diagram.
 Example) TO DSP : Refer to the reference model's service manual.
 TO CPU : Refer to this service manual.

4.5 IRIS & AF/ZOOM AND VIDEO OUT SCHEMATIC DIAGRAMS

5
4
3
2
1

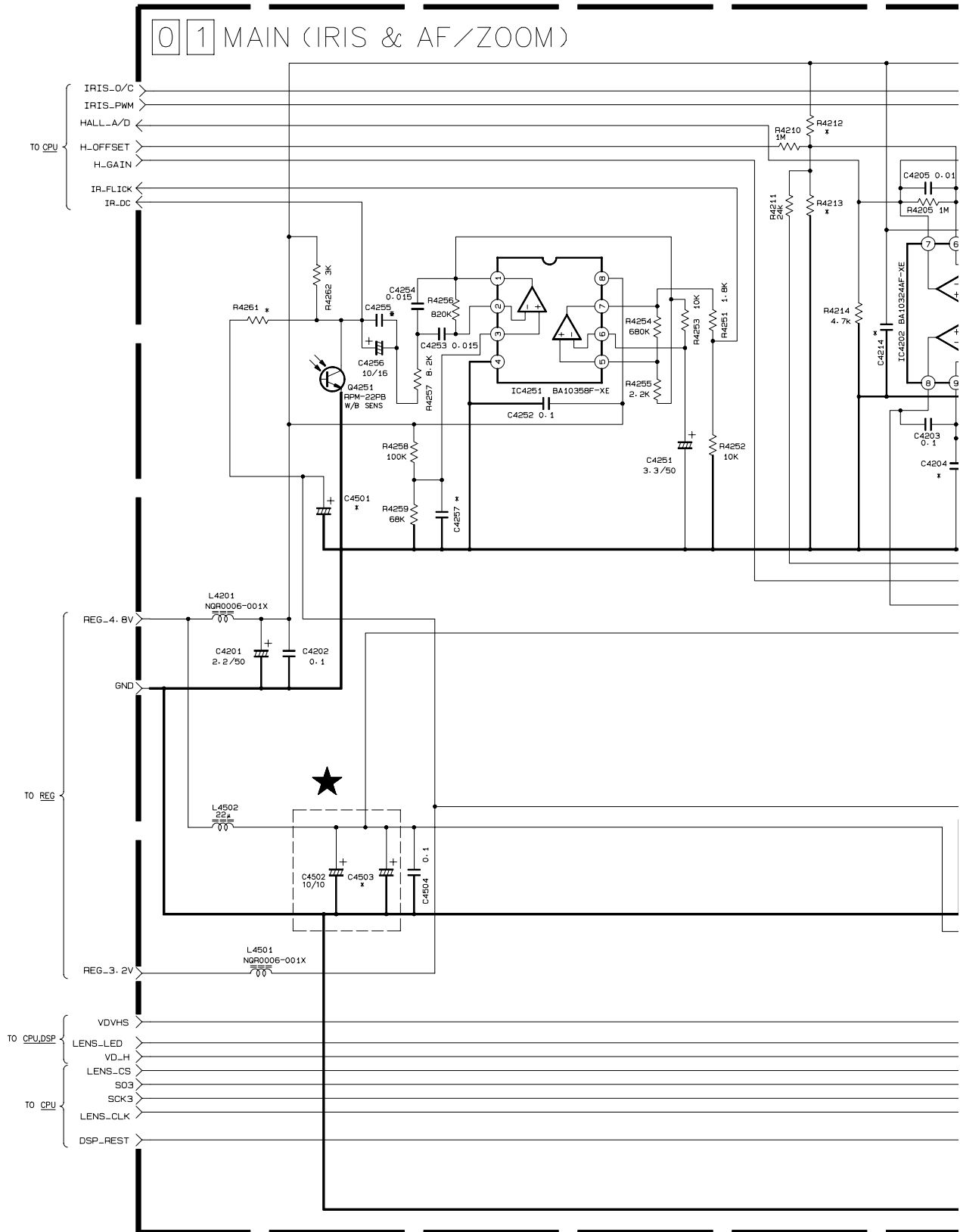

NOTES : 1. THE PARTS WITH MARKED (*) IS NOT USED. 2. The mark ★ means modified points.

A

B

C

D

- NOTES:**
- For the destination of each signal and further line connections that are cut off from this diagram, refer to "4.1 BOARD INTERCONNECTIONS".
 - When ordering parts, be sure to order according to the Part Number indicated in the Parts List.

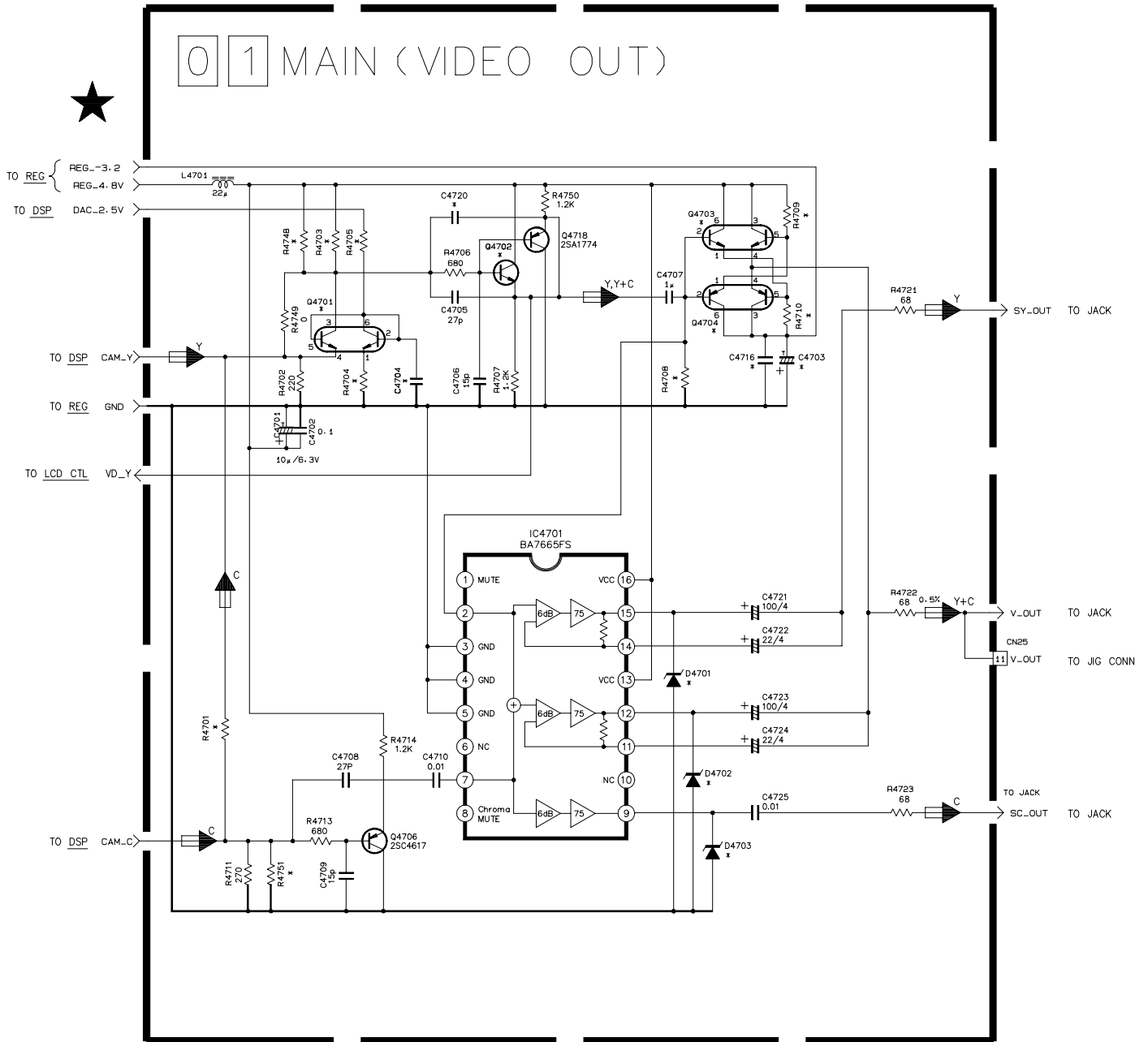

NOTE : 1.THE PARTS WITH MARKED (*) IS NOT USED.
 2.The mark ★ means modified points.

y30116001a_rev0.3

Note : How to fins the page showing the continuative schematic diagram.
 Example) TO DSP : Refer to the reference model's service manual.
 TO DSP : Refer to this service manual.

4.6 REGULATOR SCHEMATIC DIAGRAM

5

4

3

2

1

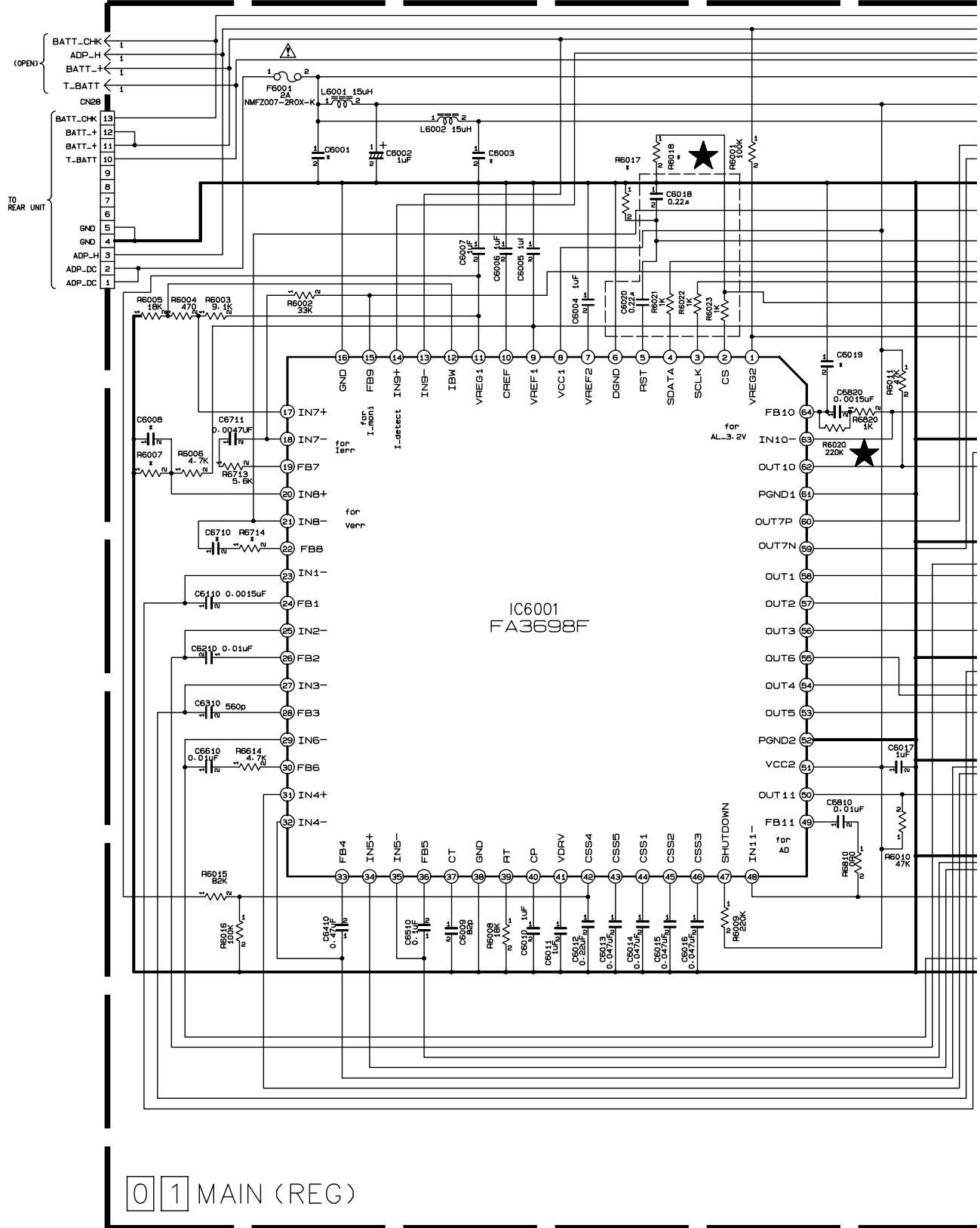

0 1 MAIN (REG)

NOTES : 1. THE PARTS WITH MARKED (*) IS NOT USED. EXCHANGE LIST
 2. The mark ★ means modified points.

CCD VOLTAGE

CCD VOLTAGE	PAL	
picture elements	LOW	others
memory	NO	
D6616	8.2V	5.1V

A B C D

- NOTES:**
- For the destination of each signal and further line connections that are cut off from this diagram, refer to “4.1 BOARD INTERCONNECTIONS”.
 - When ordering parts, be sure to order according to the Part Number indicated in the Parts List.

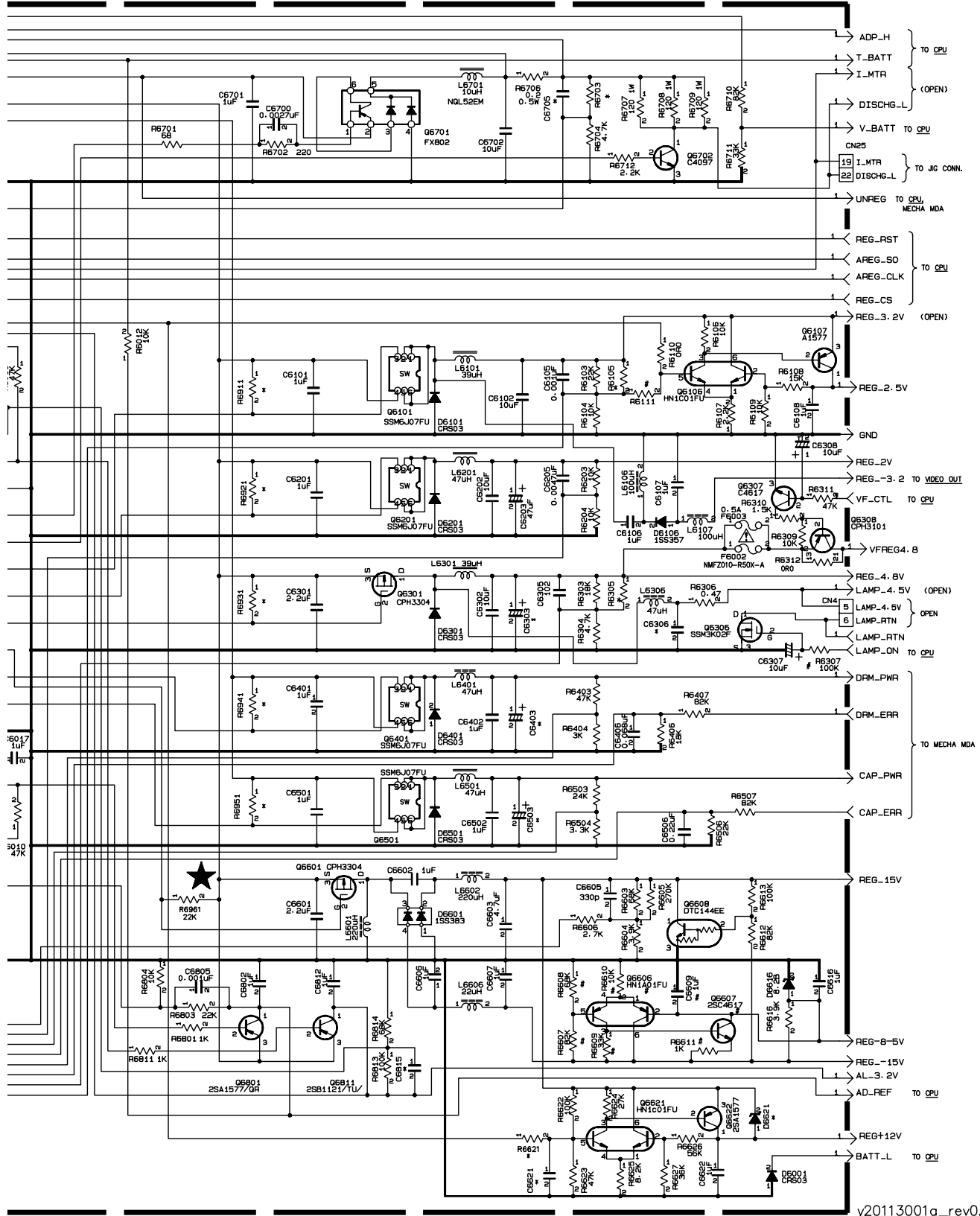

y20113001a_rev.0.1

Note: How to fins the page showing the continuative schematic diagram.
 Example) TO DSP : Refer to the reference model's service manual.
 TO DSP : Refer to this service manual.

4.7 LCD CTL SCHEMATIC DIAGRAM

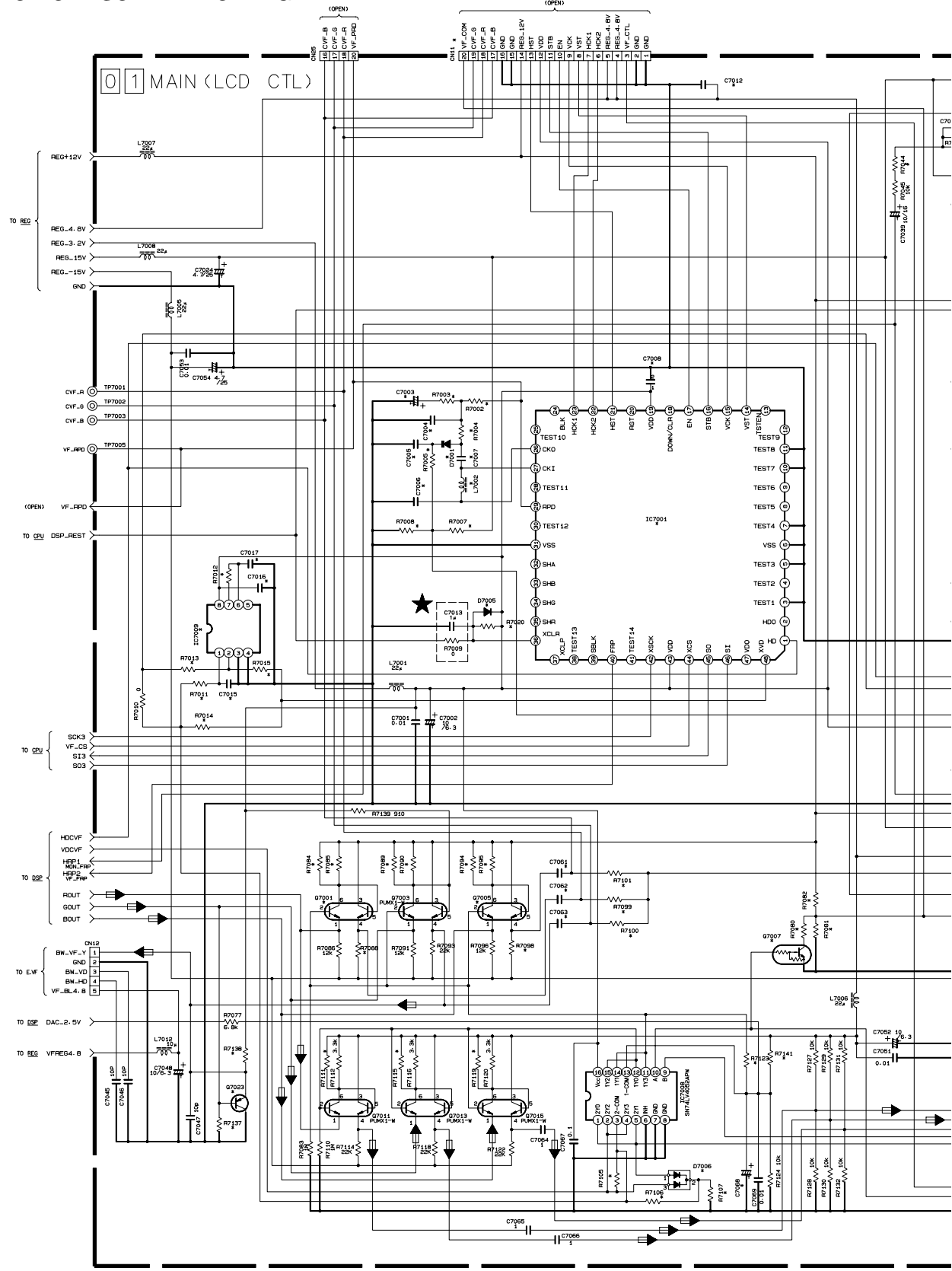

NOTES : 1. THE PARTS WITH MARKED (*) IS NOT USED. 2. The mark ★ means modified points.

A B C D

- NOTES:**
- For the destination of each signal and further line connections that are cut off from this diagram, refer to "4.1 BOARD INTERCONNECTIONS".
 - When ordering parts, be sure to order according to the Part Number indicated in the Parts List.

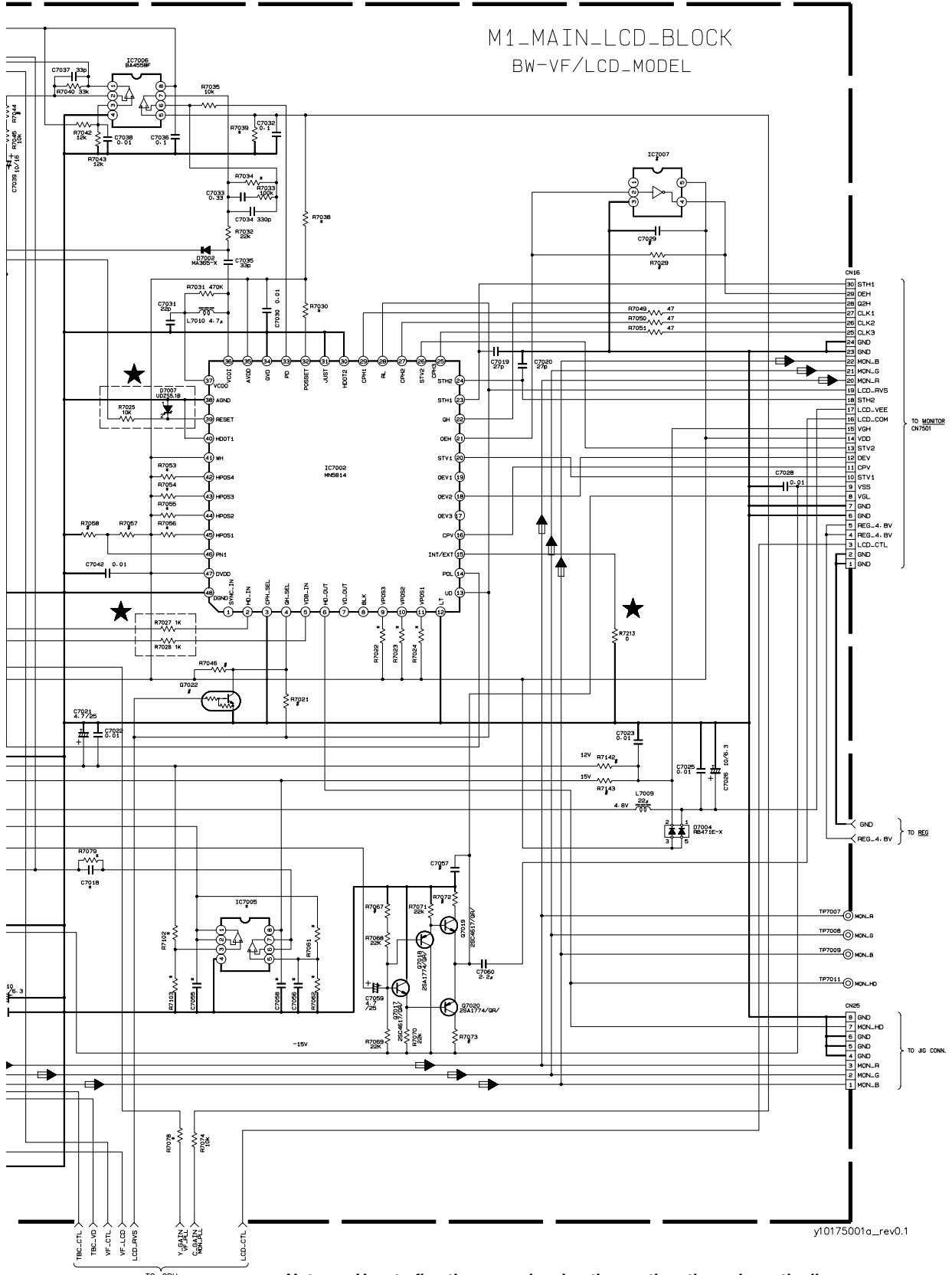

Note : How to fins the page showing the continuative schematic diagram.
Example) TO DSP : Refer to the reference model's service manual.
 TO DSP : Refer to this service manual.

E F G H

4.8 SPEAKER AND MONITOR SCHEMATIC DIAGRAMS

5
4
3
2
1

-SPEAKER-

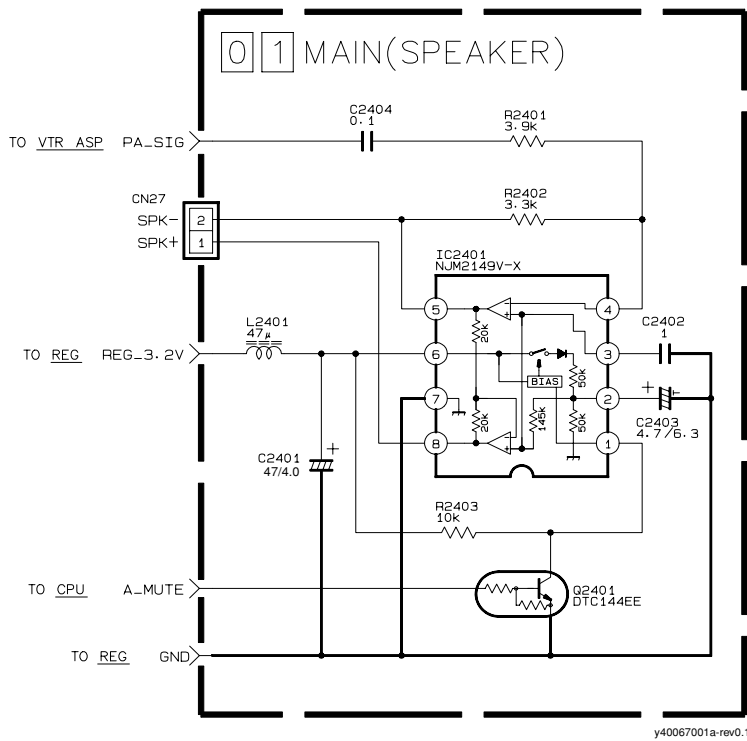

y40067001a-rw0.1

TO LCD_CTL
CN16

-MONITOR-

07 MONITOR

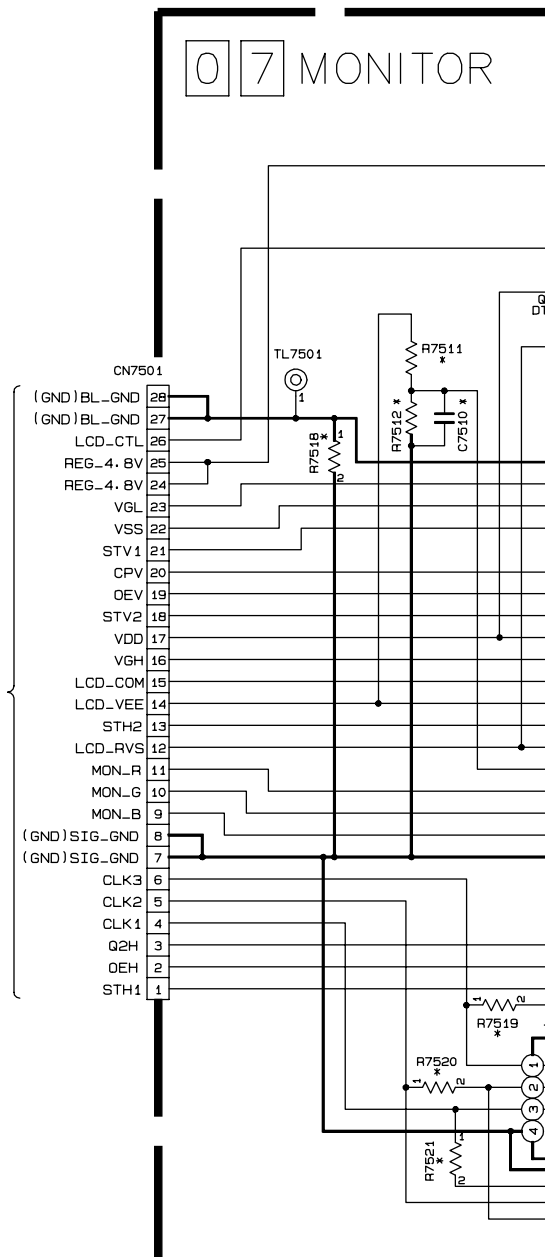

NOTES : 1. THE PARTS WITH MARKED (*) IS

A B C D

- NOTES:**
- For the destination of each signal and further line connections that are cut off from this diagram, refer to “4.1 BOARD INTERCONNECTIONS”.
 - When ordering parts, be sure to order according to the Part Number indicated in the Parts List.

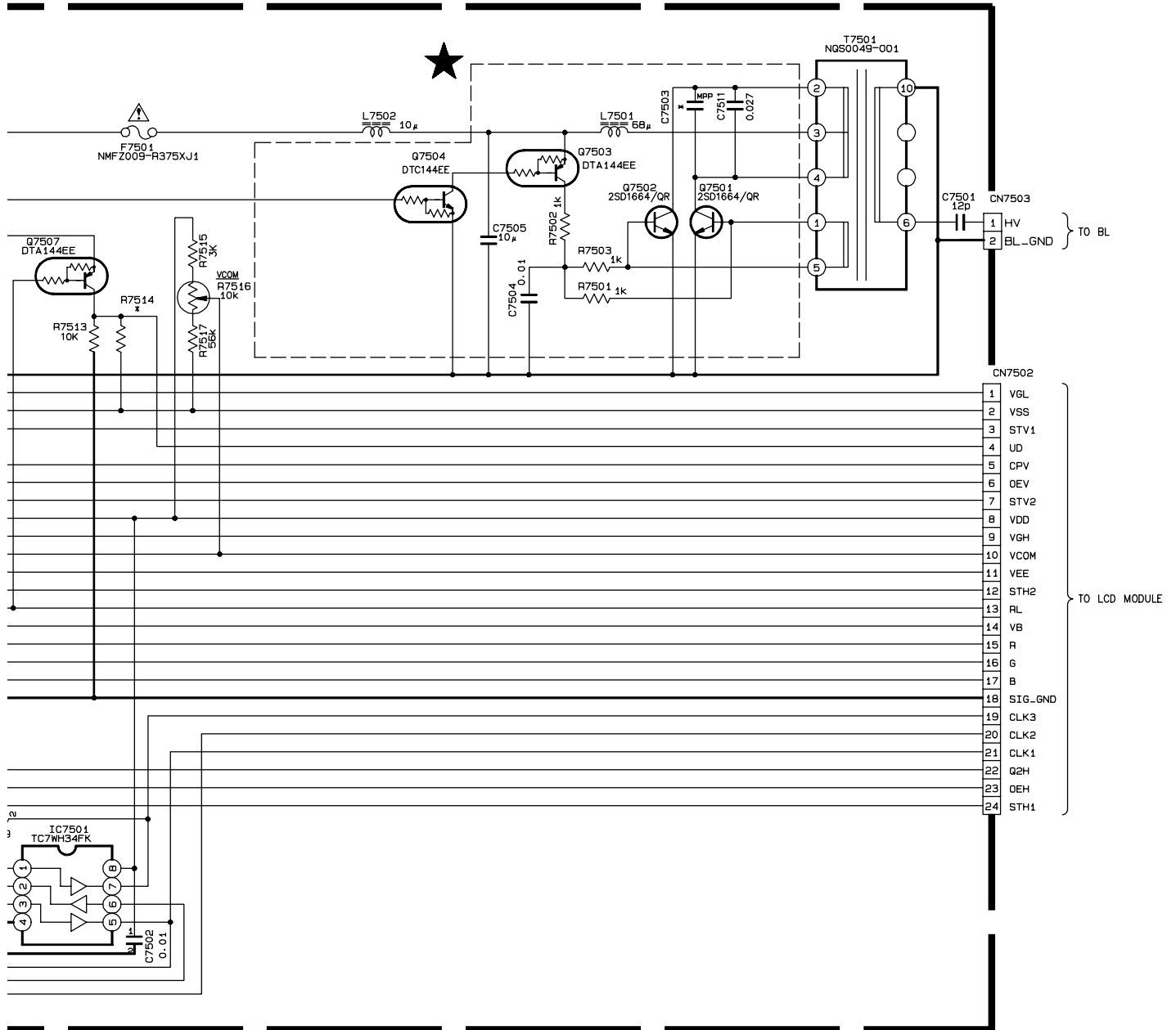

IS NOT USED.

2. The mark ★ means modified points.

y30113001a_rev.0.1

Note : How to fins the page showing the continuative schematic diagram.
Example) TO DSP : Refer to the reference model's service manual.
 TO DSP : Refer to this service manual.

E

F

G

H

4.9 MAIN CIRCUIT BOARD

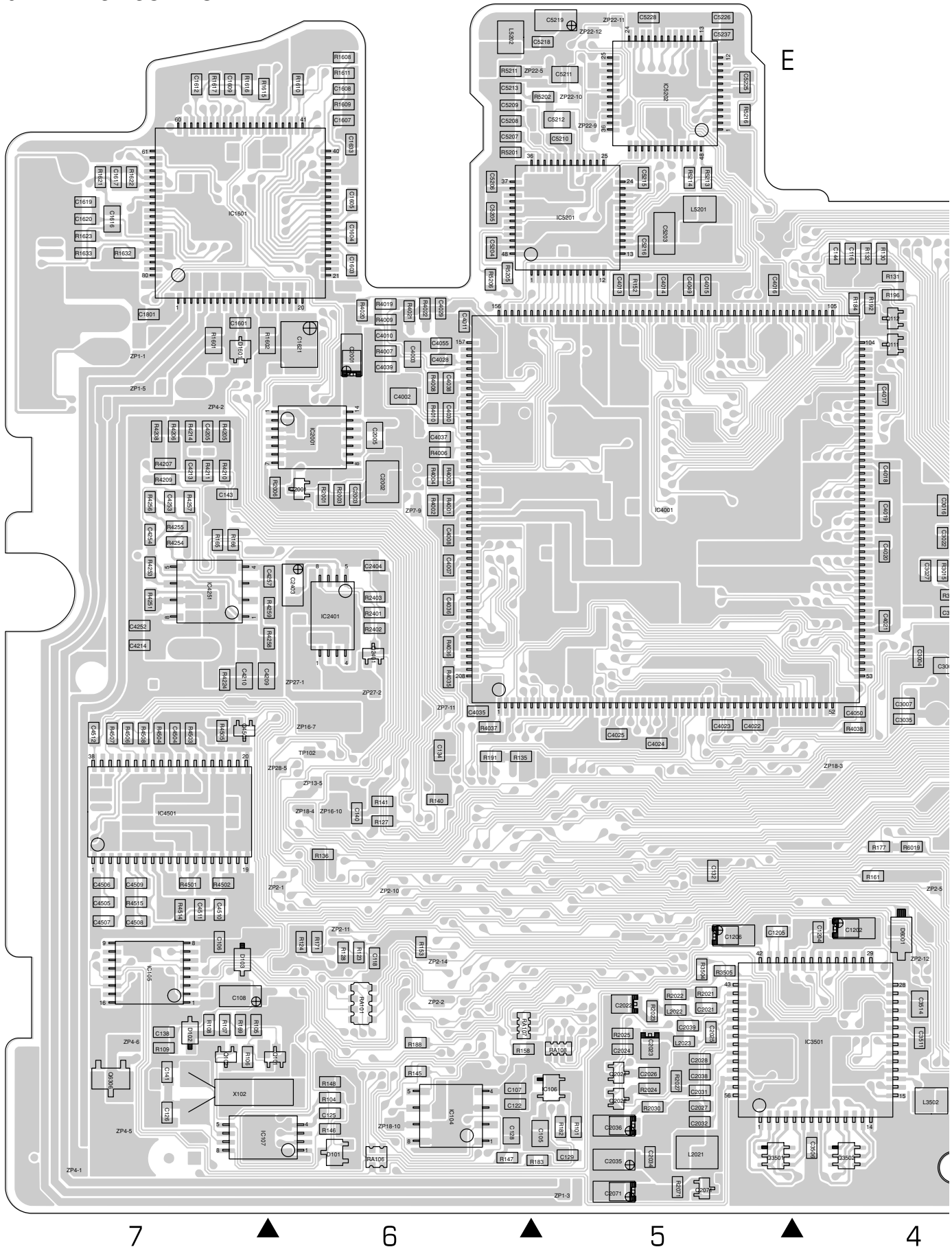

FOIL SIDE (B)

01 MAIN PWB
YB10310-01-04

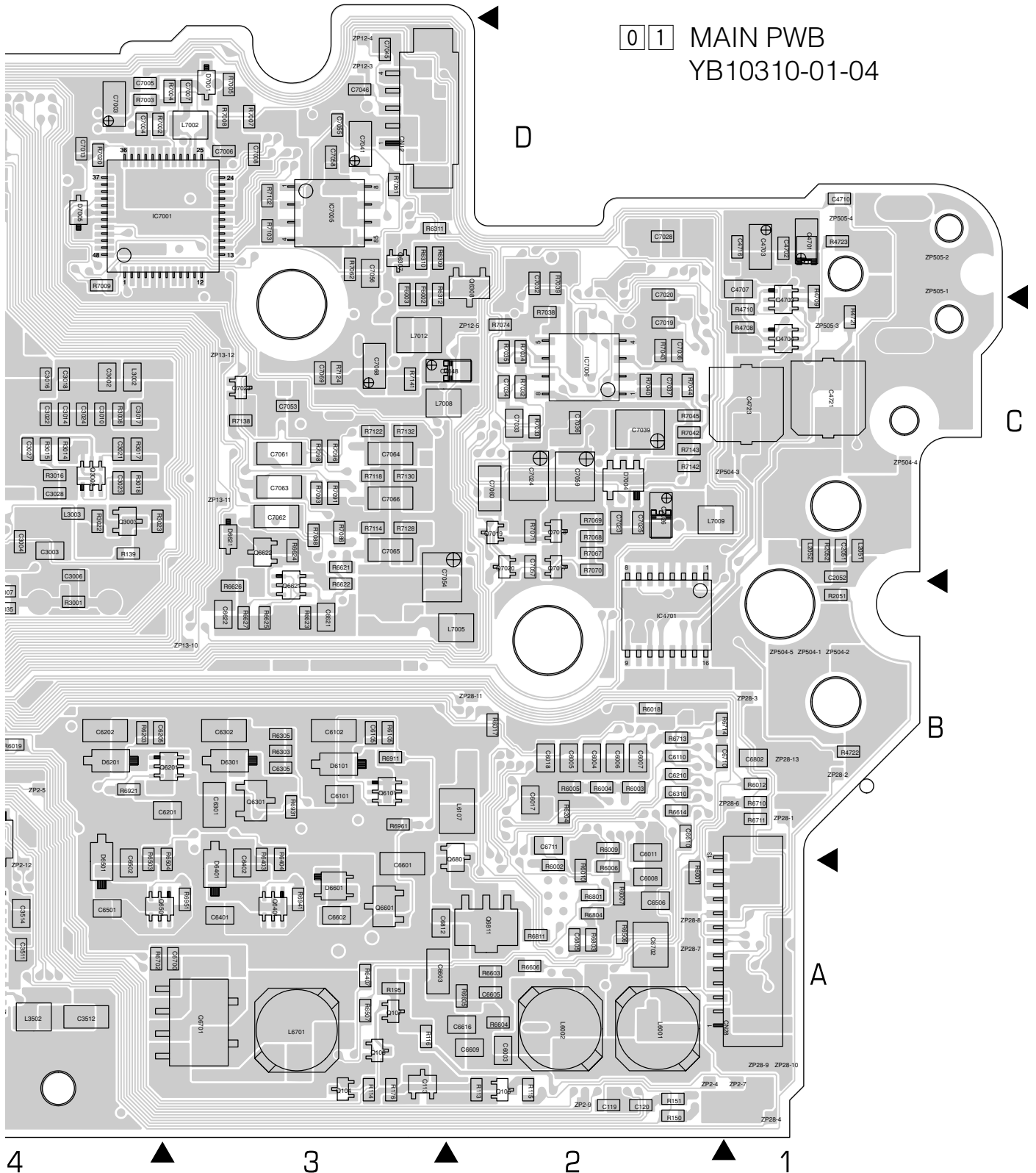

COMPONENT SIDE (A)

01 MAIN PWB
YB10310-01-04

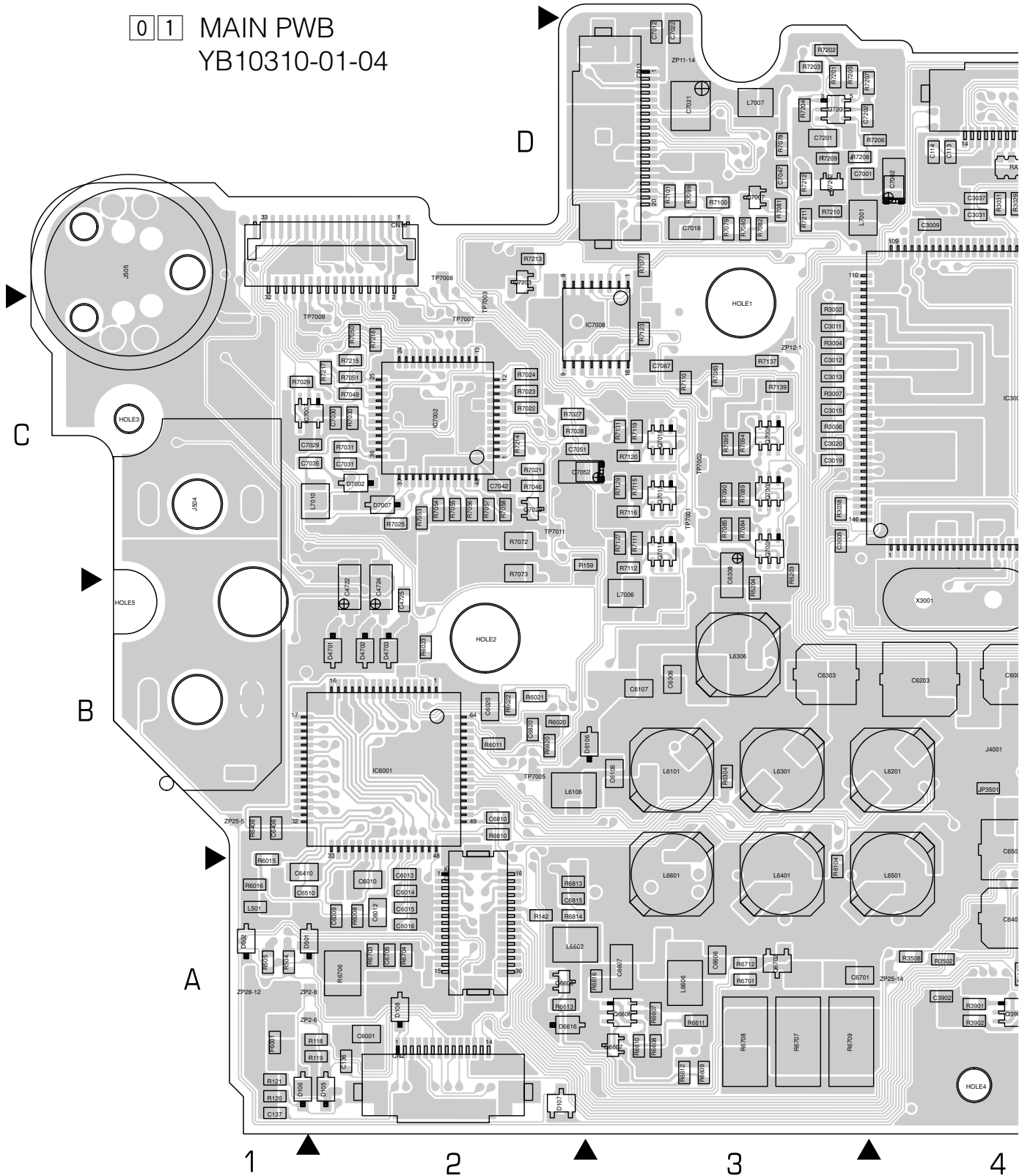

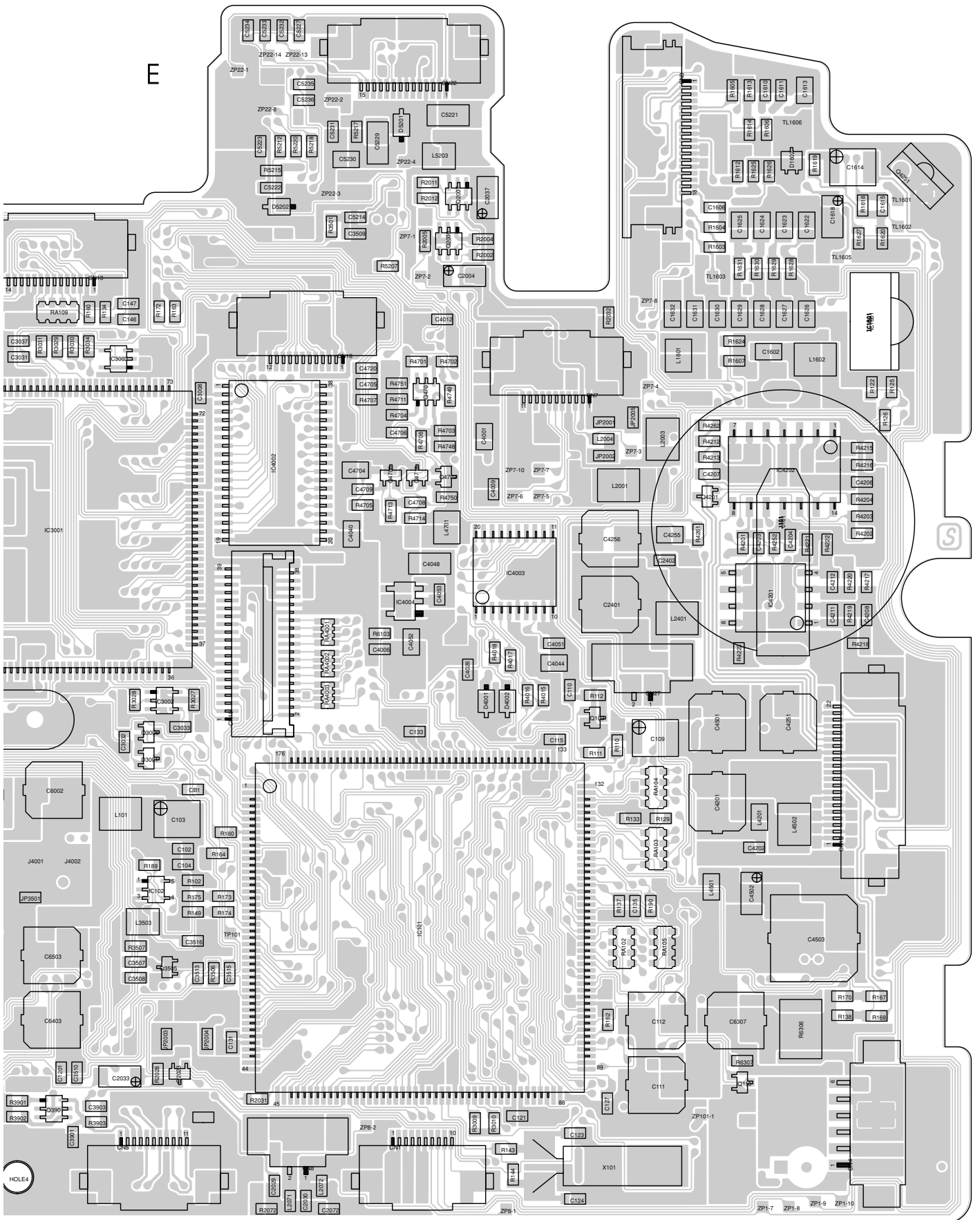

4

5

6

7

4.10 MONITOR CIRCUIT BOARD

FOIL SIDE (B)

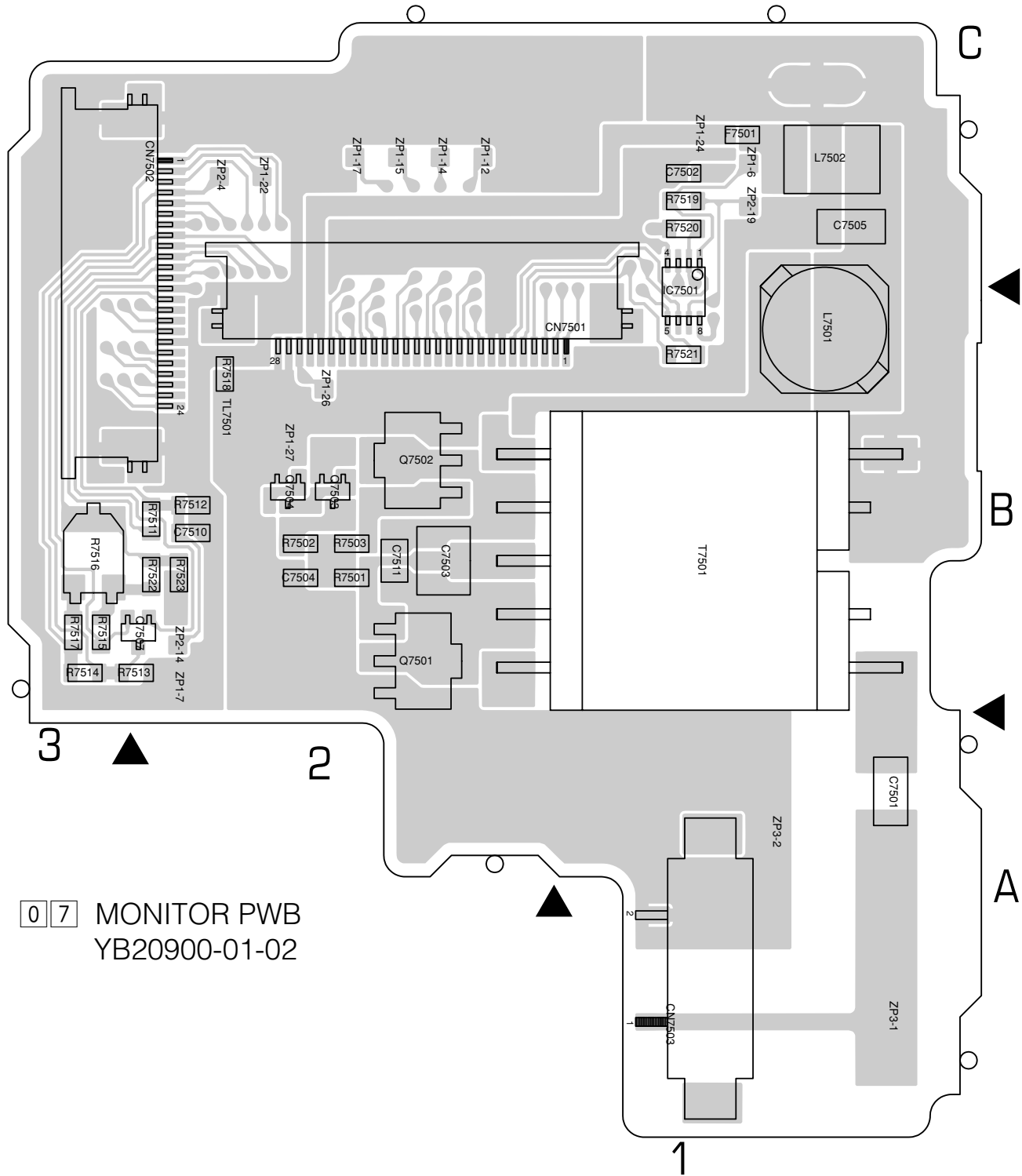

07 MONITOR PWB
YB20900-01-02

COMPONENT PARTS LOCATION GUIDE (MONITOR)

REF.No.	LOCATION	REF.No.	LOCATION	REF.No.	LOCATION	REF.No.	LOCATION	REF.No.	LOCATION	REF.No.	LOCATION	
CAPACITOR				CONNECTOR				OTHER				
C7501	B C 1A	CN7501	B C 1B	L7501	B C 1B	R7501	B C 2B	T7501	B C 1B	ZP1-15	B C 2C	
C7502	B C 1C	CN7502	B C 2C	L7502	B C 1C	R7502	B C 2B	TL7501	B C 2B	ZP1-17	B C 2C	
C7503	B C 2B	CN7503	B C 1A	TRANSISTOR				R7503	B C 2B	ZP1-22	B C 2C	
C7504	B C 2B					Q7501	B C 2B	R7504	B C 2B	ZP1-24	B C 1C	
C7505	B C 1C	FUSE				Q7502	B C 2B	R7505	B C 2B	ZP1-26	B C 2B	
C7510	B C 2B	F7501	B C 1C	Q7503	B C 2B	R7511	B C 2B	R7512	B C 2B	ZP1-27	B C 2B	
C7511	B C 2B	IC				Q7504	B C 2B	R7513	B C 2B	ZP2-14	B C 2B	
				IC7501	B C 1C	Q7507	B C 2B	R7514	B C 3B	ZP2-19	B C 1C	
								R7515	B C 3B			
								R7516	B C 3B			
								R7517	B C 3B			
								R7518	B C 2B			
								R7519	B C 1C			
								R7520	B C 1C			
								R7521	B C 1B			
								R7522	B C 2B			
								R7523	B C 2B			
								ZP1-6	B C 1C			
								ZP1-7	B C 2B			
								ZP2-4	B C 2C			
								ZP3-1	B C 1A			
								ZP3-2	B C 1A			
								ZP1-12	B C 2C			
								ZP1-14	B C 2C			

COMPONENT SIDE (A)

